

Installation, Operation and Maintenance Manual

Please read and save these instructions. Read carefully before attempting to assemble, install, operate or maintain the product described. Protect yourself and others by observing all safety information. Failure to comply with instructions could result in personal injury and/or property damage! Retain instructions for future reference.

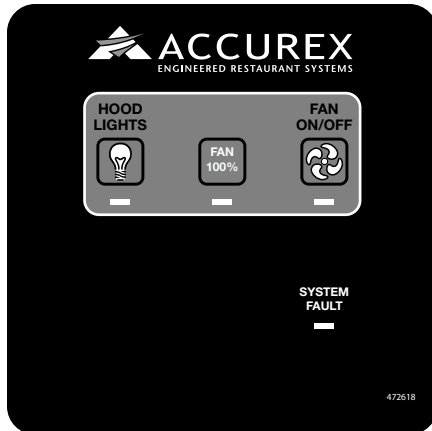

General Safety Information

Only qualified personnel should install this unit. Personnel should have a clear understanding of these instructions and should be aware of general safety precautions. Improper installation can result in electric shock, possible injury due to coming in contact with moving parts, as well as other potential hazards. Other considerations may be required if high winds or seismic activity are present. If more information is needed, contact a licensed professional engineer before moving forward.

1. Follow all local electrical and safety codes, as well as the National Electrical Code (NEC), the National Fire Protection Agency (NFPA), where applicable. Follow the Canadian Electric Code (CEC) in Canada.
2. Do not allow the power cable to kink or come in contact with oil, grease, hot surfaces, or chemicals. Replace cord immediately if damaged.
3. Verify that the power source is compatible with the equipment.

DANGER

Always disconnect power before working on or near a unit. Lock and tag the disconnect switch or breaker to prevent accidental power up.

CAUTION

When servicing the unit, variable frequency drives (VFD's) may be hot enough to cause pain or injury. Allow motor to cool before servicing.

Table of Contents

Receiving and Handling	2
Installation	
Control Box Mounting	3
Resistive Temperature Detector	3
Pneumatic Static Pressure Kit	4
Keypad Mounting	4
Wiring	5
Wiring Diagrams	6-7
Controller Setup	8
Controller Display	9-12
Sequence of Operations	13
Daily Operations	14
Troubleshooting	15
Warranty	16

Receiving

Upon receiving the product check to make sure all items are accounted for by referencing the bill of lading to ensure all items were received. Inspect each crate for shipping damage before accepting delivery. Notify the carrier if any damage is noticed. The carrier will make notification on the delivery receipt acknowledging any damage to the product. All damage should be noted on all the copies of the bill of lading which is countersigned by the delivering carrier. A Carrier Inspection Report should be filled out by the carrier upon arrival and the Traffic Department. If damaged upon arrival, file claim with carrier. Any physical damage to the unit after acceptance is not the responsibility of Accurex.

Unpacking

Verify that all required parts and the correct quantity of each item have been received. If any items are missing, report shortages to your local representative to arrange for obtaining missing parts. Sometimes it is not possible that all items for the unit be shipped together due to availability of transportation and truck space. Confirmation of shipment(s) must be limited to only items on the bill of lading.

Handling

Handle in such a manner as to keep from scratching or chipping the coating. Damaged finish may reduce ability of unit to resist corrosion.

Storage

Units are protected against damage during shipment. If the unit cannot be installed and operated immediately, precautions need to be taken to prevent deterioration of the unit during storage. The user assumes responsibility of the unit and accessories while in storage. The manufacturer will not be responsible for damage during storage. These suggestions are provided solely as a convenience to the user.

INDOOR — The ideal environment for the storage of units and accessories is indoors, above grade, in a low humidity atmosphere which is sealed to prevent the entry of blowing dust, rain, or snow. Temperatures should be evenly maintained between 30°F (-1°C) and 110°F (43°C) (wide temperature swings may cause condensation and “sweating” of metal parts). All accessories must be stored indoors in a clean, dry atmosphere.

Remove any accumulations of dirt, water, ice, or snow and wipe dry before moving to indoor storage. To avoid “sweating” of metal parts allow cold parts to reach room temperature. To dry parts and packages use a portable electric heater to get rid of any moisture build up. Leave coverings loose to permit air circulation and to allow for periodic inspection.

The unit should be stored at least 3½ in. (89 mm) off the floor on wooden blocks covered with moisture proof paper or polyethylene sheathing. Aisles between parts and along all walls should be provided to permit air circulation and space for inspection.

Inspection and Maintenance during Storage

While in storage, inspect equipment once per month. Keep a record of inspection and maintenance performed.

If moisture or dirt accumulations are found on parts, the source should be located and eliminated.

REMOVING FROM STORAGE — As units are removed from storage to be installed in their final location, they should be protected and maintained in a similar fashion, until the equipment goes into operation.

Prior to installing the unit and system components, inspect the unit assembly to make sure it is in working order.

1. Check all fasteners, and accessories for tightness.



Installation

Control Box Mounting

1. Locate an area with enough space to mount the control box and fasten to the wall.

NOTE

Control Box may be factory mounted. If so, continue to the next section.

NOTE

As the control box contains the static pressure controls, this control box should be mounted in the space to be controlled. If the control box is mounted outside of this space, please refer to the Pneumatic Static Pressure Kit Installation Instructions.

Resistive Temperature Detector(s) (RTD) Mounting

NOTE

Resistive temperature detector(s) may be factory installed. If so, continue to the next section.

1. Locate flat area(s) at the top interior of the hood in front of the filters, towards the front of the hood.

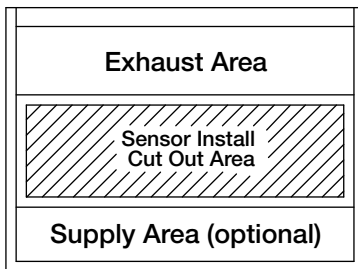

Top View of Exhaust Hood

Cut a 3/4-inch diameter hole into the top of the capture tank. Make sure the resistive temperature detector(s) will not interfere with fire system nozzles and is not within 12 inches of light fixtures.

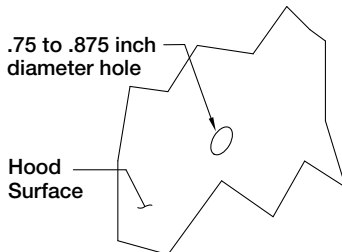

Center the octagon extension over the hole on the hood surface.

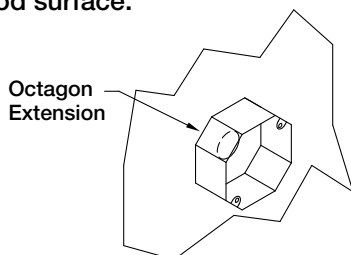

2. Insert the compression seal into the hole from the inside of the hood, making sure the gasket is placed on the fitting before inserting it into the hole. Install the lock washer and 1-1/2 inch nut on the threaded portion of the compression seals and tighten securely.

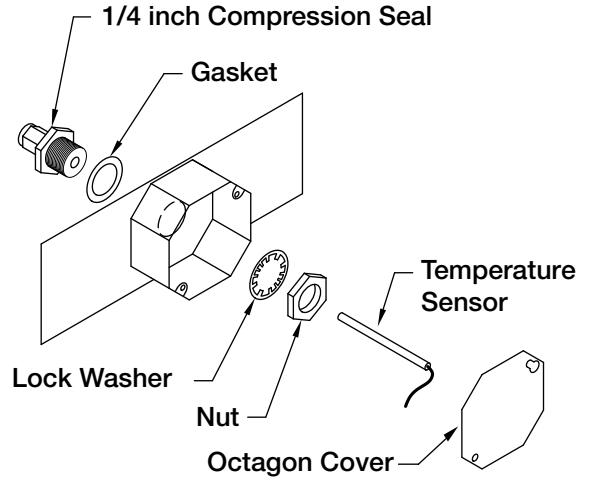

3. Place the octagon box provided over the fitting on top of the hood, keeping the fitting centered in the box.
4. Thread the resistive temperature detector (RTD) into compression seal and tighten to 35 ft-lbs.

NOTE

All field installation and wiring of electrical equipment must be done to meet NEC and local codes.

Pneumatic Static Pressure Kit

1. Locate the Dwyer static pressure sensor outside of the building in a secure location free from as many obstructions as possible.
2. Refer to the instruction manual with the static pressure sensor for installation and operation details.
3. Once the static pressure probe is mounted, run vinyl tubing from the probe back to the control panel and coil the excess tubing. Do not kink or trim the tubing.
4. If the control panel is located in the space to be controlled, go to the next section. If the control panel is mounted remotely from the space to be controlled, continue to step 5.
5. Run 1/4 inch virgin poly tubing (by others) from the sensor in the control panel to a secure location in the space to be controlled.

Keypad Mounting

NOTE

The keypad may be factory mounted. If so, continue to the next section.

1. For systems with remote controls or keypad, a 25 ft. cable is supplied to connect the keypad to the controls. The cable is plenum rated and does not need to be run through conduit unless required by local codes. If the keypad is to be mounted further than 25 ft. from the control box, additional cable will be needed. Cable is available in 25 ft. lengths from the factory.

Keypad Mounting Diagram

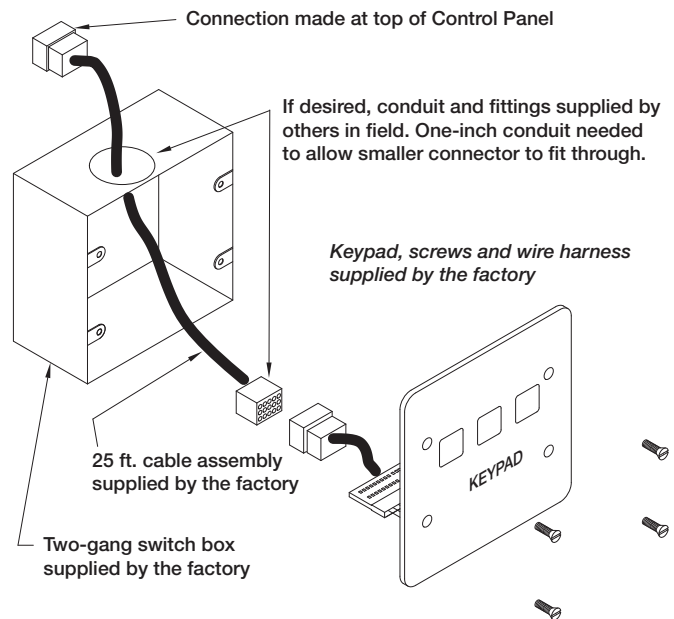

Wiring

NOTE

All field installation and wiring of electrical equipment must be done to meet NEC and local codes.

Control Box

1. Run power to the control box from two dedicated 120/1 20A breakers to the designated terminals in the control box (one for lights, one for controls).
2. If the variable frequency drives(s) are shipped loose from the control cabinet, please refer to the VFD wiring section for connection instructions to the control box.
3. For hood systems connected to a fire system, the fire system microswitch can be wired into the designated terminals of the control box for integration of fire system controls. The factory default is exhaust on, supply off in fire mode. For help with changing this parameter, please refer to the controller setup portion of this manual.

Resistive Temperature Detectors (RTD)

1. Wire the two leads of the sensors to designated terminals in the control panel as shown below. For more than four sensors see wiring diagrams page 7 or the one inside of control box door. The two wires of the sensor are not polarity sensitive. If more than one hood is being controlled, be sure that the appropriate sensor is wired in association with the appropriate hood.

NOTE

The RTD's should not be exposed to direct flame. The RTD's are rated up to 250°F

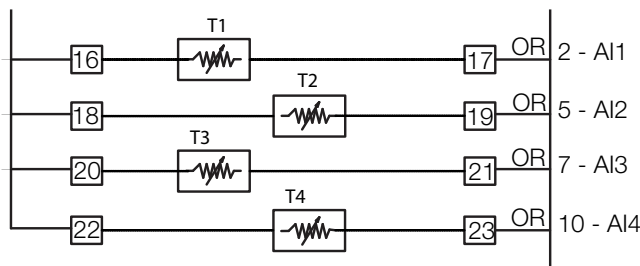

Variable Frequency Drives (VFD)

NOTE

If the VFD(s) are factory supplied and mounted in a cabinet, all interface wiring is factory supplied and this first step can be disregarded.

NOTE

If electrically commutated motors are being used, VFDs will not be needed.

1. If the variable frequency drives are remotely mounted, a six conductor 18 ga. class 2 cable must run between each VFD and the control panel.
2. Bring power to the input of each VFD from a dedicated power source using shielded conduit. Each power source shall be of the same voltage as the respective fan and of a high enough amp rating to handle the full load amp draw of the respective fan.

NOTE

The VFD full load amp setting must be set to the full load amp (FLA) draw of the respective fan. Refer to the Quick Start Guide from Yaskawa (pages 83-100) for setting this parameter on the Yaskawa drive.

NOTE

Be sure to use appropriately sized wire for the full load amp draw.

3. To avoid interference between the conductors, use separate shielded conduit to wire from the VFD output to the input power for the fan.

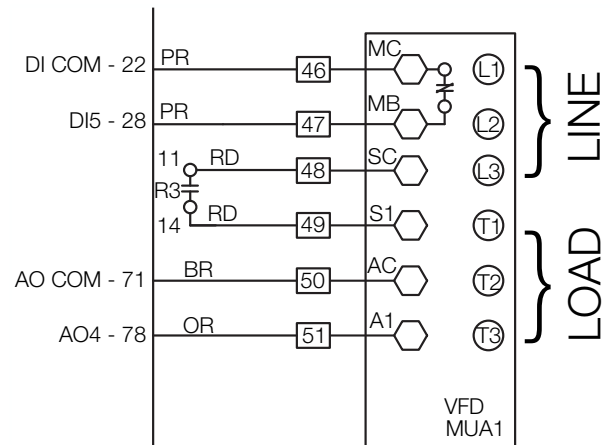

Wiring Diagram - Base System, all options

Canopy Lighting circuit must not exceed 15A total current

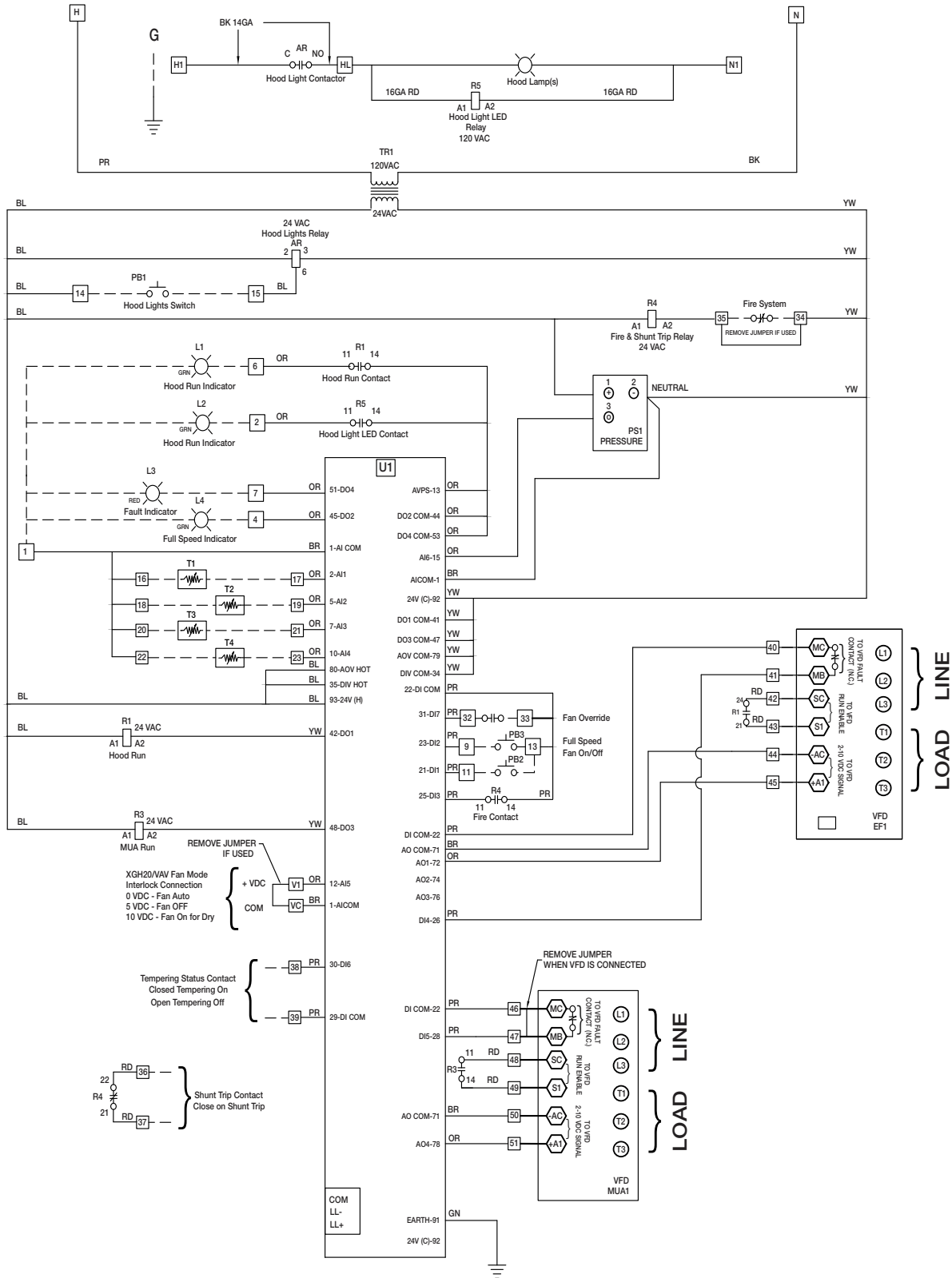

NOTE

This is an example of a wiring diagram for a base system. Controlling up to 3 exhaust fans, 1 supply fan and 4 temperature sensors. To see your job specific drawing, look on the inside panel of the Vari-Flow cabinet.



Controller Setup

This section details the process of entering the setup controls of the programmable logic controller(s) (PLCs). The controllers are factory set with standard default values which are shown in the controller settings table on pages 9-12.

Within the programmable logic controller, factory set points can be modified to configure the system for specific functions if necessary. To modify the parameters, refer to the steps provided.

NOTE

For a complete list of all settings within the Controller UL, please refer to the FX15 Vari-Flow Controller Display tables on pages 9-12.



Controller U1

1. To view factory default settings for the controller, scroll through the respective controller menus using the up and down arrow buttons.
2. To modify settings for a Controller U1 press the escape (ESC) button on the controller to navigate to the “Accounts” menu and follow the subsequent steps.
3. Press return while “Accounts” is displayed. When “User: GFC” appears, press the return button.
4. Enter the first character of the password (password is 3637) by using the up and down arrow buttons. When the appropriate value is displayed, press return. Continue until the entire four digit password has been entered.
5. Once the password has been successfully entered, press ESC and the display will return to the main menu. Continue to scroll through the menus using the left and right arrow buttons, enter a menu by pressing the return button. Scroll within the menus using the up and down arrow buttons.
6. To back out of any menu, press the escape (ESC) button.



FX15 Vari-Flow Controller Display

Accounts			
Menu	Descriptors/Value	Default	Use
Log In	GFC	GFC	Password is 3637
Events			
			The events menu is empty unless a system fault has occurred. If it has, then the system fault will be listed in the events menu.
Temperature Sensors			
Sensor Temperature			
T1	°F	-	The temperature of sensor T1
T2	°F	-	The temperature of sensor T2
T3	°F	-	The temperature of sensor T3
T4	°F	-	The temperature of sensor T4
T5	°F	-	The temperature of sensor T5
T6	°F	-	The temperature of sensor T6
T7	°F	-	The temperature of sensor T7
T8	°F	-	The temperature of sensor T8
Temperature Sensor on EF-1*			
T1 to EF-1	No / Yes	Yes	Indicates if T1 is linked to EF-1
T2 to EF-1	No / Yes	No	Indicates if T2 is linked to EF-1
T3 to EF-1	No / Yes	No	Indicates if T3 is linked to EF-1
T4 to EF-1	No / Yes	No	Indicates if T4 is linked to EF-1
T5 to EF-1	No / Yes	No	Indicates if T5 is linked to EF-1
T6 to EF-1	No / Yes	No	Indicates if T6 is linked to EF-1
T7 to EF-1	No / Yes	No	Indicates if T7 is linked to EF-1
T8 to EF-1	No / Yes	No	Indicates if T8 is linked to EF-1
Temperature Sensor on EF-2*			
T1 to EF-2	No / Yes	No	Indicates if T1 is linked to EF-2
T2 to EF-2	No / Yes	No	Indicates if T2 is linked to EF-2
T3 to EF-2	No / Yes	No	Indicates if T3 is linked to EF-2
T4 to EF-2	No / Yes	No	Indicates if T4 is linked to EF-2
T5 to EF-2	No / Yes	No	Indicates if T5 is linked to EF-2
T6 to EF-2	No / Yes	No	Indicates if T6 is linked to EF-2
T7 to EF-2	No / Yes	No	Indicates if T7 is linked to EF-2
T8 to EF-2	No / Yes	No	Indicates if T8 is linked to EF-2
Temperature Sensor on EF-3*			
T1 to EF-3	No / Yes	No	Indicates if T1 is linked to EF-3
T2 to EF-3	No / Yes	No	Indicates if T2 is linked to EF-3
T3 to EF-3	No / Yes	No	Indicates if T3 is linked to EF-3
T4 to EF-3	No / Yes	No	Indicates if T4 is linked to EF-3
T5 to EF-3	No / Yes	No	Indicates if T5 is linked to EF-3
T6 to EF-3	No / Yes	No	Indicates if T6 is linked to EF-3
T7 to EF-3	No / Yes	No	Indicates if T7 is linked to EF-3
T8 to EF-3	No / Yes	No	Indicates if T8 is linked to EF-3

* To see values, you need to log in (see instructions on page 8).



Temperature Sensors - continued			
Temp Sensor on EF-4*	Descriptors/Value	Default	Use
T1 to EF-4	No / Yes	No	Indicates if T1 is linked to EF-4
T2 to EF-4	No / Yes	No	Indicates if T2 is linked to EF-4
T3 to EF-4	No / Yes	No	Indicates if T3 is linked to EF-4
T4 to EF-4	No / Yes	No	Indicates if T4 is linked to EF-4
T5 to EF-4	No / Yes	No	Indicates if T5 is linked to EF-4
T6 to EF-4	No / Yes	No	Indicates if T6 is linked to EF-4
T 7 to EF-4	No / Yes	No	Indicates if T7 is linked to EF-4
T8 to EF-4	No / Yes	No	Indicates if T8 is linked to EF-4
Temperature Sensor on EF-5*			
T1 to EF-5	No / Yes	Yes	Indicates if T1 is linked to EF-5
T2 to EF-5	No / Yes	No	Indicates if T2 is linked to EF-5
T3 to EF-5	No / Yes	No	Indicates if T3 is linked to EF-5
T4 to EF-5	No / Yes	No	Indicates if T4 is linked to EF-5
T5 to EF-5	No / Yes	No	Indicates if T5 is linked to EF-5
T6 to EF-5	No / Yes	No	Indicates if T6 is linked to EF-5
T7 to EF-5	No / Yes	No	Indicates if T7 is linked to EF-5
T8 to EF-5	No / Yes	No	Indicates if T8 is linked to EF-5
Temperature Sensors Connected			
T1?	No / Yes	Yes	Indicates if T1 is connected
T2?	No / Yes	No	Indicates if T2 is connected
T3?	No / Yes	No	Indicates if T3 is connected
T4?	No / Yes	No	Indicates if T4 is connected
Temperature Interlock (IMC Compliance)			
IMC Settings*			
IMC Enabled			If set to yes, IMC Interlock feature is enabled. Exhaust fan will start if hood temperature exceeds the IMC Interlock set point and will run until the hood temperature falls below set point for 15 minutes.
Set point	°F	140°F	If the temperature of the hood exceeds this set point, the exhaust fan will start automatically regardless of the operating mode of the fan selected by the operator.
Make-Up Air			
Make-Up Air Set Points*			
Pressure	Inches of WC x 100	-	Differential air pressure measured from the control space to the outside or adjacent room.
MUA Speed	%	-	The actual output speed for the MUA
Tempering Status	On / Off	Off	Displays whether the MUA is heating or cooling
MUA Mode	Pres / Trak	Pres	Indicates the operating mode of the MUA
Set Point	Inches of WC x 100	50	The desired space pressure set point. (adjustable from -.10"WC to + .10"WC)

* To see values, you need to log in.



Make-Up Air - continued			
Make-Up Air Set Point*	Descriptors/Value	Default	Use
Min Speed Set	%	50%	The minimum output control limit for the MUA VFD or damper set. Must be set to a value that ensures proper design full flow CFM (Adjustable from 0% to 100%)
Max Speed Set*	%	100%	The maximum output control limit for the MUA VFD or damper set. Must be set to a value that ensures proper design full flow CFM. (Adjustable from 0% to 100%)
Tempering Set*	%	66%	Minimum run percentage for the MUA when heating or cooling is being used.

Fault Menu (No Settings)

Faults			
System Fault			Indicates that there is a fault due to the following.
Fire			Status of contact input from fire alarm system. Closed contact allows the fan to run.
Temp Fail			Indicates that one of the temperature sensors used to control the hood exhaust has failed.
Pressure Fail			Indicates that the pressure sensor has failed.
Exh VFD Fault			Status of exhaust fan VFD(s) fault contacts. Open if failed.
MUA VFD Fault			Status of MUA fan VFD(s) fault contacts. Open if failed.

Exhaust

Exhaust Fan Speed*			
EF1 Speed	%	-	Indicates the speed at which Exhaust Fan 1 is running
EF2 Speed	%	-	Indicates the speed at which Exhaust Fan 2 is running
EF3 Speed	%	-	Indicates the speed at which Exhaust Fan 3 is running
EF4 Speed	%	-	Indicates the speed at which Exhaust Fan 4 is running
EF5 Speed	%	-	Indicates the speed at which Exhaust Fan 5 is running
EF Min. Fan Speed*			
EF1 Min	0-100%	50%	Indicates the minimum fan speed to achieve positive hood capture for EF1
EF2 Min	0-100%	50%	Indicates the minimum fan speed to achieve positive hood capture for EF2
EF3 Min	0-100%	50%	Indicates the minimum fan speed to achieve positive hood capture for EF3
EF4 Min	0-100%	50%	Indicates the minimum fan speed to achieve positive hood capture for EF4
EF5 Min	0-100%	50%	Indicates the minimum fan speed to achieve positive hood capture for EF5

* To see values, you need to log in.



Exhaust			
EF Max Fan Speed	Descriptors/Value	Default	Use
EF1 Max	%	100%	Indicates the maximum fan speed to meet design airflow requirements for EF1
EF2 Max	%	100%	Indicates the maximum fan speed to meet design airflow requirements for EF1
EF3 Max	%	100%	Indicates the maximum fan speed to meet design airflow requirements for EF1
EF4 Max	%	100%	Indicates the maximum fan speed to meet design airflow requirements for EF1
EF5 Max	%	100%	Indicates the maximum fan speed to meet design airflow requirements for EF1
Exhaust Temperature Set Points*			
EF1 TempSet	°F	90%	The desired hood temperature set point for EF1 (adjustable from 70° to 140°F)
EF2 TempSet	°F	90%	The desired hood temperature set point for EF2 (adjustable from 70° to 140°F)
EF3 TempSet	°F	90%	The desired hood temperature set point for EF3 (adjustable from 70° to 140°F)
EF4 TempSet	°F	90%	The desired hood temperature set point for EF4 (adjustable from 70° to 140°F)
EF5 TempSet	°F	90%	The desired hood temperature set point for EF5 (adjustable from 70° to 140°F)
Exhaust Mode			
Fans Full Speed?	No / Yes	-	Indicates the operator overrode the exhaust fan to full speed operation
Time Left	Minutes	-	Indicates the time remaining for the full speed override
Exhaust in Fire?	No / Yes	Yes	Indicates the exhaust fan(s) will run in case of fire
Exhaust Fans*			
Fan1 Connected	No / Yes	Yes	Indicates if EF1 is connected
Fan1 Connected	No / Yes	No	Indicates if EF2 is connected
Fan1 Connected	No / Yes	No	Indicates if EF3 is connected
Fan1 Connected	No / Yes	No	Indicates if EF4 is connected
Fan1 Connected	No / Yes	No	Indicates if EF5 is connected
Grease Grabber H2O with Vari-Flow Settings			
XGH20/VF Settings	Descriptors/Value	Default	Use
XGH20 Force Fan Off?	No / Yes	No	If yes the exhaust fan(s) are forced off to prevent water from being drawn into the exhaust duct during the wash cycle. The fan button on the keypad is disabled.
XGH20 Fan Dry Active?	No / Yes	No	If yes, the exhaust fan(s) is(are) forced on to dry the filters following the wash cycle.
XGH20 Fan Mode			
	0-10-VDC	-	0 V-Fan(s) Auto
	0-10-VDC	-	5 V-Fan(s) Off
	0-10-VDC	-	10 V-Fan(s) Dry

* To see values, you need to log in.



SEQUENCE OF OPERATION - VARI-FLOW

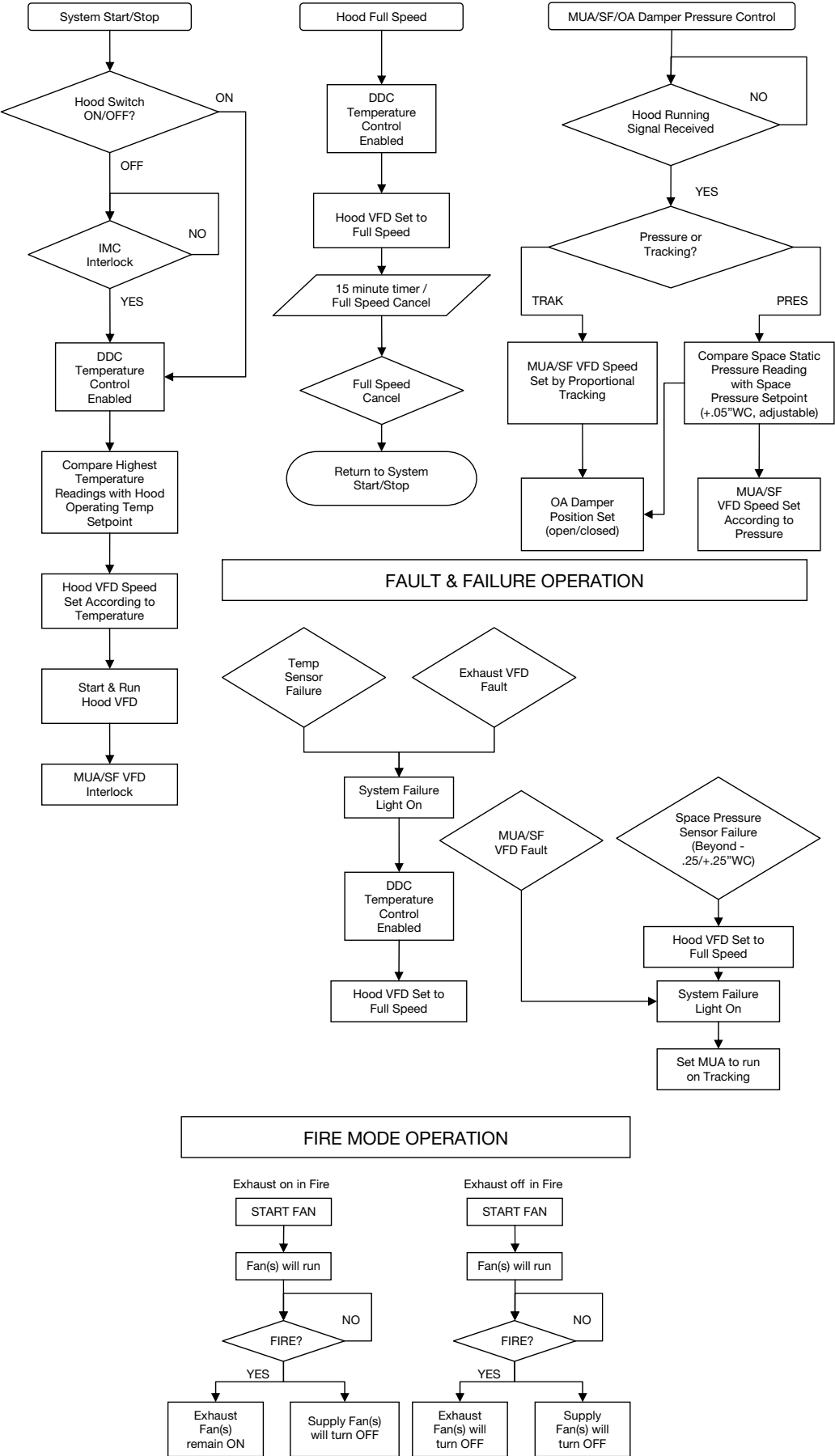

Daily Operations of Vari-Flow System

The following section details the buttons on the Vari-Flow keypad and their function as it relates to the daily operation of the system.

Hood Lights - Momentarily pressing the 'Hood Lights' button will turn on all lights for the respective hood(s) attached to the system. A green LED light will illuminate under the Hood Lights button indicating power to the lights. Pressing the 'Hood Lights' button again will turn off the lights for the respective hood(s). The green LED light will no longer be illuminated.

Fan On/Off- Momentarily pressing the 'Fan On/Off' button will turn on the fan(s) (exhaust and supply where applicable) for the respective hood(s) attached to the system. A green LED light will illuminate under the Fans On/Off button indicating power to the fans. The fans will start at a minimum speed and vary automatically based on heat load generated by the appliances.

Fan 100% - Momentarily pressing the 'Fan 100%' button while the fans are operating will send the fan speed for the entire system to 100% for 15 minutes (adjustable) or until the Fan 100% button is pressed again. Pressing the Fan 100% button again will take the fans out of 100% operation and return them to standard operating conditions.

NOTE

When Vari-Flow is operating in temperature interlock mode the fan 100% LED will flash. During this time the fans may be manually turned on by pressing the on/off button.

NOTE

In the event of a potential system fault, the display will turn on an event message describing the fault. This info can be used in servicing the fault.

LED Display Guide (LED's on face of Programmable Logic Controller U1)

Indicator	Operation	Detail
Power	Power	When LED is lit the controller is powered on.
Alarm	Alarm	When LED is lit the system is experiencing a fault.
1	Exhaust Fan Run	When LED is lit the controller is commanding the exhaust fans to run.
2	Supply Fan Run	When LED is lit the controller is commanding the supply fans to run.
3	Supply Fan Heat/Cool	When the LED is lit the supply fan is operating in heating or cooling.
4	Pressure Sensor Fault	When LED is lit the pressure sensor is experiencing a fault.
5	Fire	When LED is lit the system is operating in fire mode.
6	Temperature Sensor Fault	When LED is lit the controller is not receiving a correct reading from the temperature sensor.
7	Exhaust VFD Fault	When LED is lit the exhaust VFD is experiencing a fault.
8	Supply Fan VFD	When LED is lit the supply VFD is experiencing a fault.



Troubleshooting Guide

Issue	Possible Cause	Recommended Solution
Smoke spilling out of hood at 100% operation	High speed set too low	Increase exhaust fan maximum speed (up to 100%)
	Improper hood design	Check hood overhang, cross drafts, or proper make up air
Smoke spilling out when hood running at lowest speed	Fan minimum speed set too low	Increase exhaust fan minimum speeds
	Improper hood design	Check hood overhang, cross drafts and proper make up air
Fans do not turn down to minimum speed	Dirty temperature sensor	Clean grease from temperature sensor
	Temperature set point too high	Decrease the temperature set point (90°F default)
Fans do not turn down to minimum speed	Dirty temperature sensor	Clean grease from temperature sensor
	Temperature set point too low	Increase the temperature set point (90°F default)
Exhaust fan on and supply fan does not	Broken supply fan belt	Replace fan belt
	Fire mode	Check fire contact connection
Fans rotate in wrong direction	VFD output wiring incorrect	Switch any two leads on the hood side of the VFD to the fan motor
100% override does not increase exhaust	Exhaust already at 100%	Proper Operation
	Bad wiring connection	If fan 100% LED does not light check keypad connection
Fan switch on but no fans come on	Broken fan belt	Replace fan belt
	VFD fault	Check VFD for faults
	Bad wiring connection	If fan on/off LED does not light check keypad connection
Hood lights LED on but no lights come on	Light bulbs are burnt out	Replace hood light bulbs
	Bad wiring connection	If hood lights LED is lit check wiring connection to hood lights
Fan 100% LED is flashing	Vari-Flow is operating in temperature interlock mode	Press the Fan On button to manually turn on the fans
Fans do not turn on automatically	Temperature interlock is set to off	Turn the temperature interlock operation on
	Interlock set point too high	Adjust the temperature interlock set point
Pressure Sensor Fault	Kinked hose	Remove kink or replace hose
	Controlled space not holding pressure	Adjust the static pressure set point
Fire	Fire system microswitch is in the fire position	Check the fire suppression microswitch connections
Temperature Sensor Fault	Dirty/burnt sensor	Clean/replace sensor
	Incorrect programming	Check the temperature sensor settings
Exhaust VFD Fault	VFD overcurrent	Fan rotating in the wrong direction
	Fan FLA not set in the VFD parameters	Check the VFD overload settings
Supply VFD Fault	VFD overcurrent	Fan rotating in the wrong direction
	Fan FLA not set in the VFD parameters	Check the VFD overload settings



Warranty

Accurex warrants this equipment to be free from defects in material and workmanship for a period of one year from the shipment date. Any units or parts which prove defective during the warranty period will be replaced at our option when returned to our factory, transportation prepaid. Motors are warranted by the motor manufacturer for a period of one year. Should motors furnished by Accurex prove defective during this period, they should be returned to the nearest authorized motor service station. Accurex will not be responsible for any removal or installation costs.

As a result of our commitment to continuous improvement, Accurex reserves the right to change specifications without notice.

AMCA Publication 410-96, Safety Practices for Users and Installers of Industrial and Commercial Fans, provides additional safety information. This publication can be obtained from AMCA International, Inc. at www.amca.org.



Phone: 800.333.1400 • Fax: (715) 241-6171 • Web site: www.accurex-systems.com