

Installation, Operation, and Maintenance Manual

**MODEL XUEB
Series 200**

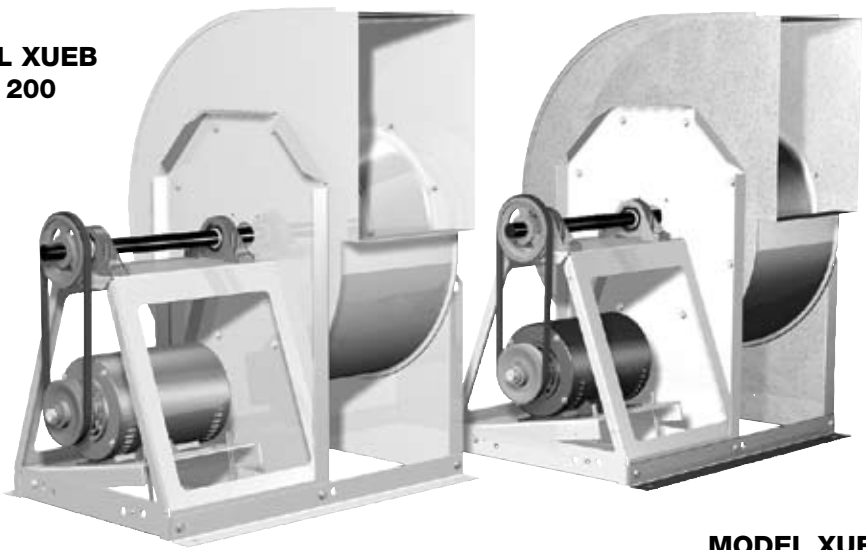

**MODEL XUEB
Series 100**

TABLE OF CONTENTS

MOTOR AND DRIVE INSTALLATION (UNITS SHIPPED FROM STOCK)	2
INSTALLATION	3
AFFECT OF INSTALLATION ON PERFORMANCE	3
UL/cUL 762 - RESTAURANT EXHAUST	4
PRE-STARTING CHECKS	4 - 5
BELT DRIVE FAN MAINTENANCE	6
BEARING LUBRICATION SCHEDULE	6
MOTOR MAINTENANCE (BELT AND DIRECT DRIVE)	6
PARTS LIST	7
TROUBLESHOOTING CHART	8

Please read and save these instructions for future reference. Read carefully before attempting to assemble, install, operate or maintain the unit. Failure to comply with instruction could result in personal injury and/or property damage!

Upon receiving unit, check for any damage that may have occurred during transit and report it immediately to the shipper. Also check to see that all accessory items are accounted for.

MOTOR AND DRIVE INSTALLATION INSTRUCTIONS

(Model XUEB units are shipped from stock without motors or drives)

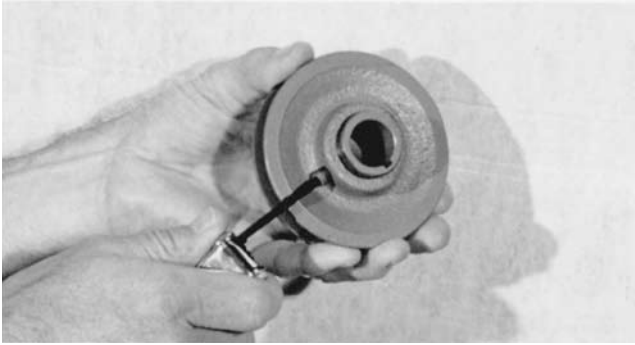

1. Adjust motor pulley to its closed position for maximum fan speed or increments of 1/2 turn open (maximum of 5 turns open) for reduced fan speed. Tighten set screw on flat area only.

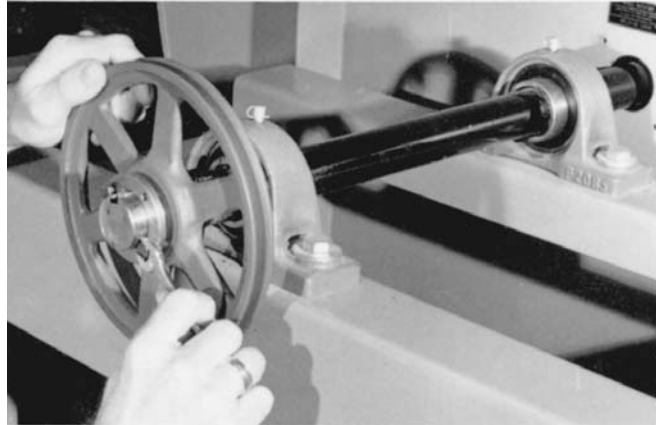

4. Install shaft pulley to fan shaft.



2. Install motor pulley to the motor shaft and install motor to the motor plate. Prepunched holes are provided for most common motor frame sizes.

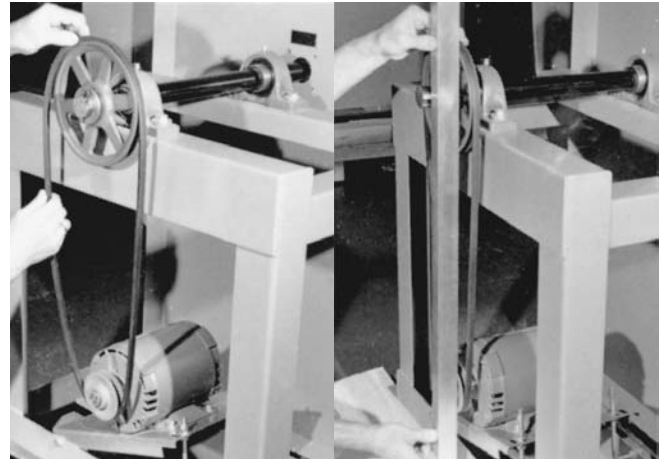

5. Install drive belt(s). Belts should not be forced over pulleys. Align motor and shaft pulleys with a straight edge. Tighten all set screws.



3. If supplied, install taperlock bushing into shaft pulley.



6. Adjust belt tension. See page 6 for belt tensioning instructions.

INSTALLATION

Inspect the unit for any damage and report it to the shipper immediately. Also, check to see that all accessory items are accounted for.

Move the fan to the desired location and fasten securely through mounting holes provided in the base angles. The unit must be set level (shimming may be necessary). Flexible duct connections and vibration isolators should be used where noise is a factor.

The motor voltage and ampere rating must be checked for compatibility with the electrical supply prior to final electrical connection. Supply wiring to the fan must be properly fused and conform to local and national electrical codes.

The discharge is factory set as specified by customer order, however, it can be rotated to other discharge positions in the field if necessary. Removal of the housing bolts allows the discharge to be rotated to the clockwise positions below (Fig. 1). For TAD, BD and BAD discharge positions a portion of the frame angle must be removed.

VIEWED FROM DRIVE SIDE OF THE FAN

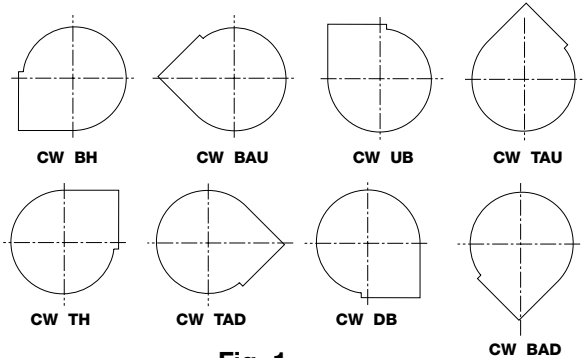

Fig. 1

Clockwise rotation shown. Counterclockwise discharge positions are a mirror image of those shown. The XUEB 100 Series is clockwise rotation only. Fan rotation is always viewed from the drive side of the housing.

AFFECT OF INSTALLATION ON PERFORMANCE

Restricted or unstable flow at the fan inlet can cause pre-rotation of incoming air or uneven loading of the fan wheel, yielding large system losses, increased sound levels and structural failure of the fan wheel. Free discharge or turbulent flow in the discharge ductwork will also result in system effect losses.

The examples below show the system layout and inlet and discharge configurations which can affect fan performance.

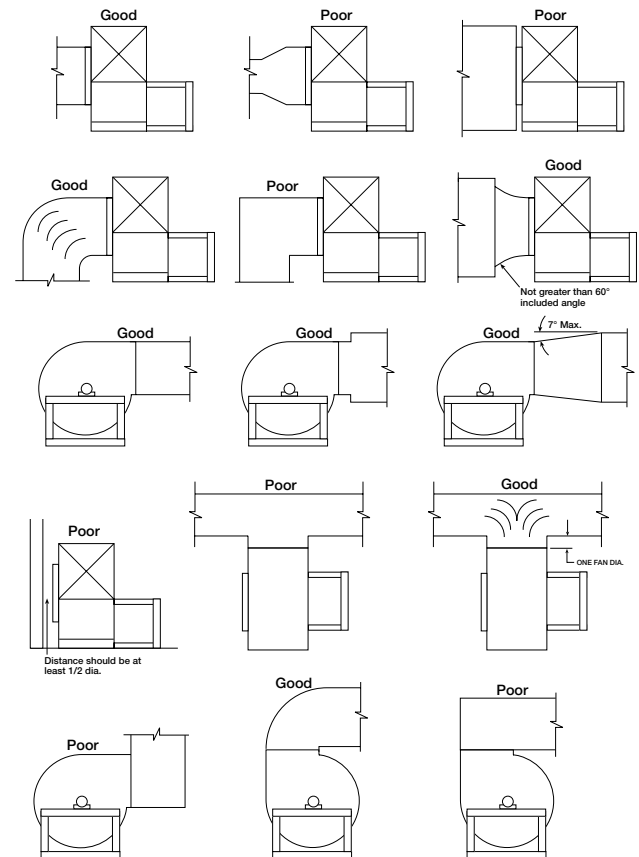

INSTALLATION OF UL/cUL 762 LISTED FANS FOR RESTAURANT EXHAUST

The UL/cUL 762 listing for restaurant exhaust is available on XUEB 200 Series fan sizes 10-36 with a weatherhood. UL/cUL 762 fans are listed for a maximum operating temperature of 375°F and include a bolted access door and 1 in. drain connection. An outlet guard is strongly recommended when the fan discharge is accessible. An upblast discharge is recommended. The fan discharge must be a minimum of 40 in. above the roof line and the exhaust duct must be fully welded to a distance of 18 in. above the roof surface.

This drawing is for dimensional information only. See the latest edition of NFPA 96 Standard for Ventilation Control and Fire Protection of Commercial Cooking Operations for detailed installation instructions, materials, duct connections and clearances.



Series 200 XUEB models are listed for grease removal (UL/cUL 762) File no. MH11745.

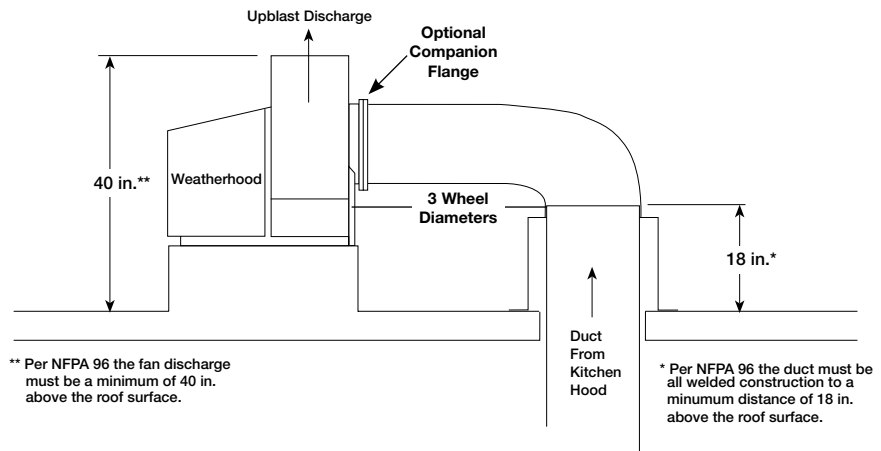

PRE-STARTING CHECKS

Wheels must rotate freely and not rub on the inlet venturi. Model XUEB wheels overlap the inlet venturi as shown in Figure 2. Refer to the XUEB fan wheel overlap and radial gap chart for proper dimensions.

Unit Size	XUEB		
	Overlap (inches)		Radial Gap (inches)
	Series 100	Series 200	
6	-	-	-
7	-	-	-
9	-	-	-
10	3/8	1/4	5/32
12	3/8	-	5/32
13	7/16	1/4	5/32
15	1/2	1/4	5/32
16	1/2	1/4	5/32
18	5/8	3/8	5/32
20	5/8	3/8	5/32
22	11/16	-	5/32
24	3/4	3/8	5/32
25	-	-	-
27	7/8	-	3/16
30	15/16	1/2	3/16
33	1 1/16	-	3/16
36	1 3/16	1/2	3/16

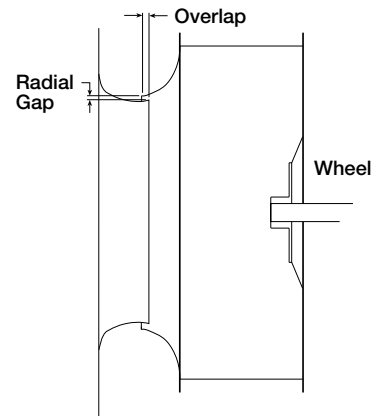

MODEL XUEB

Fig. 2

On belt drive units, centering can be accomplished by (1) loosening the inlet cone bolts to move the inlet cone or by (2) loosening the bearings in order to move the shaft. Wheel and inlet cone overlap can be adjusted by loosening the wheel hub set screw and moving the wheel to the desired position. Tighten all fasteners and set screws securely and realign drive pulleys after adjustment. Check pulleys and belts for proper alignment to avoid unnecessary belt wear, noise, vibration and power loss. Motor and drive shafts must be parallel and pulleys in line (Fig. 4)

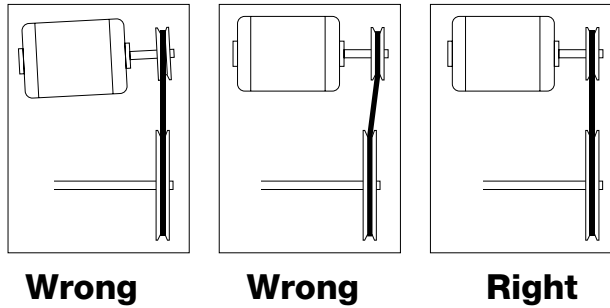

Fig. 4

The adjustable motor pulley is set at the factory for the fan RPM specified by the customer. Fan RPM can be increased by closing or decreased by opening the adjustable motor pulley. Multi-groove variable pitch pulleys must be adjusted an equal number of turns open or closed. Any increase in fan speed represents a substantial increase in load on the motor.

To avoid motor overheating and possible burnout, motor load amperes should always be checked and compared to nameplate rating when fan speed is increased.

WHEELS VIEWED FROM THE DRIVE SIDE

Rotation direction of the wheel is critical and incorrect rotation will result in reduced air performance, increased motor loading and possible motor burnout

Check wheel rotation by momentarily energizing the unit and noting if rotation is in the same direction as the airflow at the outlet and conforms to the rotation decal affixed to the unit (Fig. 5).

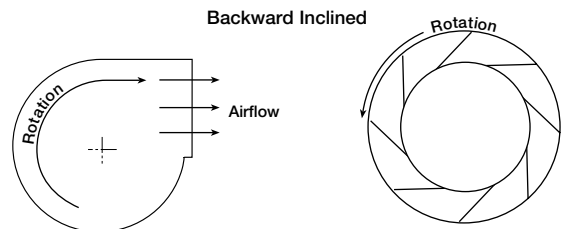

Fig. 5

WARNING!

Disconnect all electrical power to the fan and secure to the "OFF" position prior to inspection or servicing. Failure to comply with this safety precaution could result in serious injury or death.

BLOWER MAINTENANCE (BELT DRIVE)

Belts tend to stretch after a period of time. They should be periodically checked for tension and wear. When replacing belts, use the same type as supplied with the unit. Replacement of belts should be accomplished by loosening the tensioning bolts so the belts may be removed by hand. Do not force belts on or off as this may cause breakage of cords and lead to premature belt failure.

Belt tension should be adjusted to allow 1/64 in. of belt deflection per 1 in. of belt span. For example, a 16 in. belt span should have 16/64 in. or 1/4 in. of deflection with moderate thumb pressure at mid-point between the pulleys. (Fig. 6).

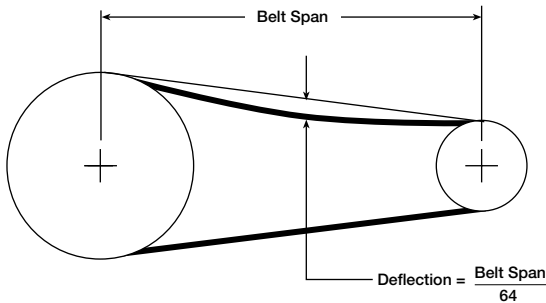

Fig. 6

Shaft bearings are the most critical moving part of a fan. Therefore, special attention should be given to keeping the bearings clean and well lubricated. Proper lubrication provides for reduction in friction and wear, transmission and dissipation of heat, extended bearing life and prevention of rust.

In order for a lubricant to fulfill these tasks, the proper grease applied at regular intervals is required. See the recommended bearing lubrication schedule. If unusual conditions exist - temperatures below 32°F or above 200°F, moisture or contaminants - more frequent lubrication is required.

BEARING LUBRICATION SCHEDULE FOR Accurex UTILITY FANS

(Relubrication schedule in months)

Fan RPM	Shaft Diameter in inches	
	3/4 to 1 1/2	1 3/4 to 2
To 500	6	6
500-1000	6	5
1000-1500	5	4
1500-2000	4	3
2000-2500	4	2
2500-3000	3	1
3000-3500	2	1

With the unit running add grease very slowly with a manual grease gun until a slight bead of grease forms at the seal.

Be careful not to unseat the seal by over lubricating or using excessive pressure. A guide to the amount of grease to be used is to fill 30% to 60% of available space in the bearing and housing.

A high quality lithium based grease conforming to NLGI Grade 2 consistency, such as those listed below, should be used.

Mobil 532
Mobilux #2
B Shell Alvania #2
Texaco Multifak #2
Texaco Premium #2
Unirex N2

In addition to lubricating the bearings at specified intervals, set screws in the bearing collars should be checked for tightness. A bearing collar which has loosened will cause premature failure of the fan shaft. Fasteners attaching the bearings to the drive frame should also be checked.

MOTOR MAINTENANCE (BELT AND DIRECT DRIVE)

Motor maintenance is generally limited to cleaning and lubrication (where applicable). Cleaning should be limited to exterior surfaces only. Removing dust and grease build-up on the motor housing assures proper motor cooling. Use caution and do not allow water or solvents to enter the motor or bearings. Under no circumstances should motors or bearings be sprayed with steam, water or solvents.

Greasing of motors is intended only when fittings are provided. Many fractional horsepower motors are permanently lubricated for life and require no further lubrication. Motors supplied with grease fittings should be greased in accordance with the manufacturer's recommendations.

WHEEL AND FASTENER MAINTENANCE

Wheels require very little attention when exhausting clean air, however air heavily laden with grease or dirt will tend to accumulate on the wheel causing unbalance. Wheels exhausting dirty or grease laden air require frequent cleaning to assure smooth and safe operation.

All fasteners, including set screws in the bearing collars, should be checked for tightness each time maintenance checks are performed.

A proper maintenance program will help preserve the performance and reliability designed into the fan.

PARTS LIST

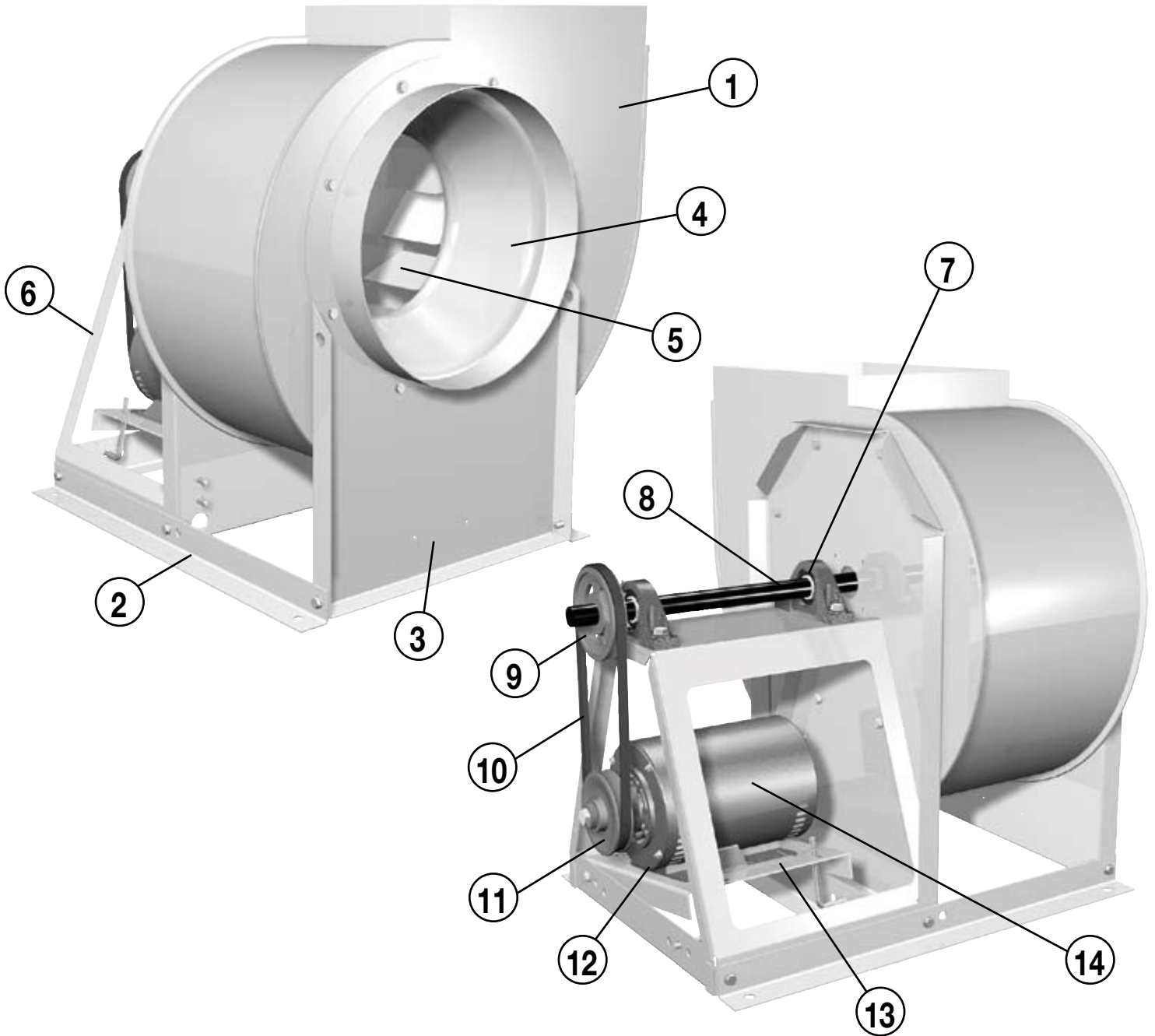

Always provide the unit model and serial number when requesting parts or information.

REPLACEMENT PARTS

- | | | |
|-----------------------------|--------------------------|---------------------------|
| 1. Scroll housing | 6. Drive frame assembly | 11. Motor pulley |
| 2. Drive frame - Base angle | 7. Pillow block bearings | 12. Belt tensioning bolts |
| 3. Intake support panel | 8. Fan shaft | 13. Motor plate |
| 4. Inlet ring and cone | 9. Shaft pulley | 14. Motor |
| 5. Wheel (Specify rotation) | 10. Belt | |

TROUBLESHOOTING

Problem	Cause	Corrective Action
Excessive Noise	Wheel Rubbing Inlet	Adjust wheel and/or inlet cone. Tighten wheel hub or bearing collars on shaft.
	V-Belt Drive	Tighten sheaves on motor/fan shaft. Adjust belt tension. Align sheaves properly (see page 4). Replace worn belts or sheaves.
	Bearings	Replace defective bearing(s). Lubricate bearings. Tighten collars & fasteners.
	Wheel Unbalance	Clean all dirt off wheel. Check wheel balance, rebalance in place if necessary.
Low CFM	Fan	Check wheel for correct rotation. Increase fan speed.*
	Duct System	See page 4.
High CFM	Fan	Decrease fan speed.
	Duct System	Resize ductwork. Access door, filters, grills not installed.
Static Pressure Wrong	Duct system has more or less restriction than anticipated	Change obstructions in system. Use correction factor to adjust for temperature/altitude. Resize ductwork. Clean filters/coils. Change fan speed.*
High Horsepower	Fan	Check rotation of wheel. Reduce fan speed.
	Duct System	Resize ductwork. Check proper operation of face and bypass dampers. Check filters and access doors.
Fan Doesn't Operate	Electrical Supply	Check fuses/circuit breakers. Check for switches off. Check for correct supply voltage.
	Drive	Check for broken belts. Tighten loose pulleys.
	Motor	Assure motor is correct horsepower and not tripping overload protector.
Overheated Bearing	Lubrication	Check for excessive or insufficient grease in the bearing.
	Mechanical	Replace damaged bearing. Relieve excessive belt tension. Align bearings. Check for bent shaft.

NOTE

Always provide the unit model and serial numbers when requesting parts or service information.

*Always check motor amps and compare to nameplate rating. Excessive fan speed may overload the motor and result in burnout.

WARRANTY

Accurex warrants this equipment to be free from defects in material and workmanship for a period of one year from the date of purchase. Any units or parts which prove to be defective during the warranty period will be replaced at our option when returned to our factory, transportation prepaid. Motors are warranted by the motor manufacturer for a period of one year. Should motors furnished by Accurex prove defective during this period, they should be returned to the nearest authorized motor service station. Accurex will not be responsible for any removal or installation costs.

As a result of our commitment to continuous improvement, Accurex reserves the right to change specifications without notice.

